



Fishmaster Folding T-Top Installation Instructions And Owners Manual

Fishmaster, Inc.
Phone: 877-777-Tower or 678-679-1462
Fax: 877-437-6210
www.Fishmaster.com
Support@Fishmaster.com
Reference 06March15

THANK YOU FOR YOUR BUSINESS. IF YOU ARE NOT COMPLETELY SATISFIED IN ANY WAY WITH YOUR NEW FISHMASTER T-TOP, PLEASE CONTACT US IMMEDIATELY. Our entire purpose as a company is to create great products at affordable prices that fishermen love.

IMPORTANT

Please take a few minutes to read the entire installation instructions and become familiar with the Fishmaster parts and installation before beginning to ensure a high quality, trouble free installation. We put a lot of effort into our manuals and are continually improving them so your feedback and suggestions are sincerely appreciated. If you have any questions during your installation give us a call at 877-777-Tower or e-mail Support@Fishmaster.com

**After installing your t-top and before you put the canvas on the frame polish it thoroughly with the supplied tube of Flitz Aluminum Polish.
Periodically apply Flitz Polish or a comparable aluminum polish to the T-Top frame to help prevent oxidizing or pitting.**

IMPORTANT NOTES ON INSTALLING AND USING YOUR NEW FISHMASTER T-TOP

- **Read the entire instruction manual before beginning.**
- If your console has a side door you may need to replace the hinge with slide in pins described later in this manual.
- Always apply a thin film of grease to threads before installing to ease installation.
- Note you are installing from the Bases up. First install the bases, then the standoffs and then the top canopy frame.
- Re-torque all hardware after each of the first few uses and then check regularly.
- The Fishmaster T-Top is silent by design, if you hear any rattling or noise at all, then check all hardware for tightness. Call us at 877-777-Tower if you continue to hear any rattling or noise before using the T-Top as this means something is not installed correctly.
- Begin by ensuring you have a protected surface to assemble the parts of the T-Top so they will not be damaged. The packaging bubble wrap works great, just spread out to create a protected work area. Grass and carpeted areas are additional options.
- Always drill in reverse, and only 1” deep and make sure you do not drill into tanks or cables.
- **Read the entire instruction manual before beginning for a fast, trouble free installation.**
- **Call us at 877-777-Tower or email us at Support@Fishmaster.com if you have any questions or concerns during the installation.**
- Send us a picture of your boat after installing your T-Top and we'll send you a free Fishmaster T-Shirt. Remember to include your shirt size and mailing address. Please email your pictures to us at Support@Fishmaster.com.

Getting to Know your Fishmaster T-Top Assembly Diagram

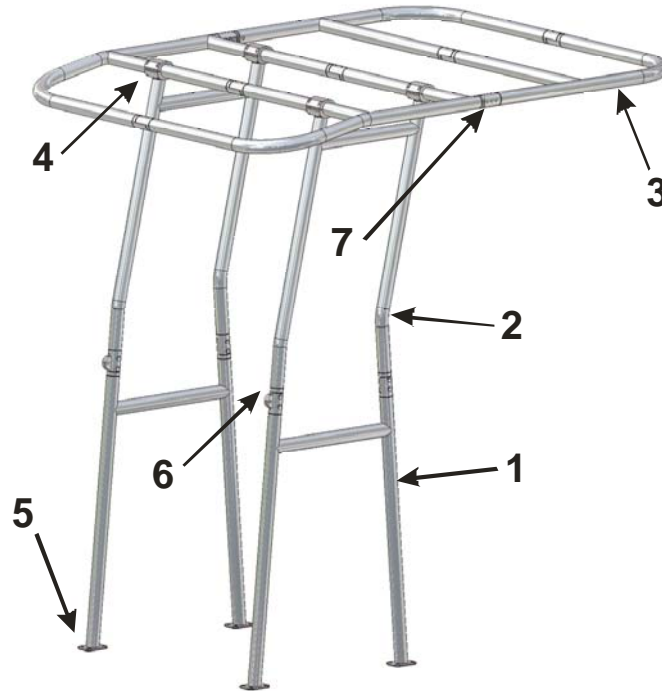

<i>Part</i>	<i>Qty</i>	<i>Description</i>
1	2	Lower Leg
2	2	Upper Leg
3	4	Canopy Frame Sections
4	4	Upper Leg Clamps
5	4	Bases
6	2	Leg Hinge
7	2	Canopy Frame Hinge
8	1	Sunbrella® Cover (not shown)
9	1	Cover Lacing Rope (not shown)

The Fishmaster T-Top is an innovative design in the T-Top market that uses many common parts and design elements that make it affordable, functional and easy to install. The two main components of the design as shown above are the side legs and the upper frame. The side legs are mirror images to provide right and left legs. These are hinged in the center to allow the T-Top to be folded forward.

The legs are typically mounted with the bolt heads to the outside for folding the T-Top down. They can also be installed with the bolts to the inside if the folding feature is not required or rarely used.

The canopy frame has four sections. The two front sections attach to the legs by the upper leg clamps. The two rear sections attach to the front sections at the canopy frame hinge as shown in the above assembly drawing. The canopy frame hinge allows the canopy frame to fold for storage.

You are now an expert on the components of the Fishmaster T-Top and we will use the terminology of the Parts List throughout this document. **Note that Parts refer to components of the T-Top and Items refer to hardware, tools and accessories.** Familiarize yourself with the below hardware items that will be used in the installation.

Fishmaster T-Top Hardware List			
<i>Item</i>	<i>Metric Dimension</i>	<i>Application</i>	<i>Qty</i>
1	M6 x 25 Socket Head Cap Screw	Attach Sides to Top	16
2	M10 x 35 Socket Head Cap Screw	All Connectors and Top Hinge	24
3	M10 x 20 Socket Head Cap Screw	Side Hinge	2
4	#14 x 1-1/2" Sheet Metal Screws	Connect Front Bases to Boat Deck	8
5	#14 x 1" Sheet Metal Screws	Connect Rear Bases to Boat Deck	8
6	M5 Head Allen Wrench	Supplied tool for M6 Cap Screws	1
7	M8 Head Allen Wrench	Supplied tool for M10 Cap Screws	1
8	Standoff Assembly (shown on Pg. 9)	Attach Sides to Center Console	2

The above hardware and tools are included with your Fishmaster T-Top and are referenced to in the installation of the tower by their item number. The following are items the customer supplies to complete the installation.

Items and tools needed for Installation

The following items will be needed for the installation of the T-Top and are not supplied.

Customer Supplied Tools

Reversible Drill

11/64" and 3/8" Drill Bits (A 3/8" x 12" wall bit is recommended for standoff installation)

Phillips head screwdriver or drill with Phillips bit

Masking Tape, Tape Measure & Pencil

Level to make sure the boat and parts are square and level during installation

Friend to help hold & hand things

Safety Glasses (always use when drilling fiberglass or metal)

Vacuum for drill shavings from mounting bases and standoffs

Rubber mallet is recommend for adjusting leg width

Center Punch is recommended to start all holes before drilling

Customer Supplied Materials

For Roplene™ boats like Triumph use "Sudbury Elastomeric Sealant" by Rule, available at your local Triumph dealer or many retailers and online stores

White Lithium or similar marine grease for rotating points and bolts

Non-Permanent Loctite for side hinge bolt and standoffs.

12 Zip Ties or pieces of twine/rope 10" or longer for centering Cover on Canopy Frame

Main Assembly

During the assembly and installation, you should protect the parts from scratches by doing the assembly on a tarp, blanket, grass, carpet or the packaging bubble wrap and cardboard. It is also recommended to put paper or cardboard on the floor of the boat to protect the boat.

Use a level to ensure the beam of the boat is level during installation. It is not important that the boat be level front to back, only side to side needs to be level. Lift the lower side of the trailer with wood or similar shims under the tires as needed. You can “eye-ball” it but it is easier to use a level to confirm the boat and uprights are square and level.

Canopy Frame Assembly: Apply a small amount of grease to sixteen (16) of the Item 2 bolts. Assemble the front two sections and rear two sections first then bolt the front and rear sections together. Apply a very thin film of grease to the mating hinges on each side of the canopy.

Side Leg Assemblies: Apply a small amount of grease to eight (8) of the Item 2 bolts. Install the Item 3 bolts into the side hinges with Loctite leaving the bolt out one turn to allow for hinge clearance. Assemble the upper and lower legs together for each side. First, attach the bolts to the front hinges. Apply a very thin film of grease between the mating surfaces of the side hinge. Next, put the bolts in the rear section of the legs. You will find that the rear legs are off set approximately 1 inch. This is to put tension on the bolts not allowing them to come loose or make noise. You will need to push the two sections together and put in the bolt.

Attach Legs to Canopy at Estimated Width: This can be most easily done on the ground and will require four people to move the T-Top into the boat. Measure the approximate width of where you will install the T-Top over your center console. This does not need to be exact and will be adjusted when you move the T-Top to the boat. Be sure the legs are wide enough to fit around the console when placed in the boat as shown below. GREASE AND LIGHTLY SNUG THE ITEM 1 BOLTS AT THIS STEP AS THEY WILL BE REMOVED LATER TO COMPLETE THE INSTALLATION.

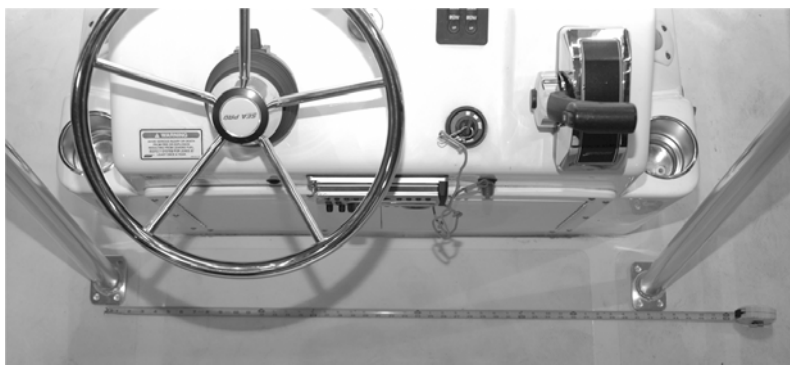

TIP: Once the Canopy Frame is assembled attached one leg first as shown below, then stand it up and attach the other leg as shown below. A second person will be needed.



Move the T-Top to the Boat: It is easiest to have two people on the ground transfer the T-Top in the vertical position to two people in the boat. With only two people one can lift the canopy frame and the second can lift at the base of the legs to transfer to the boat in the horizontal position with one leg on the side of the boat. The key is to take it slow to prevent damage to the boat or T-Top.

Align Uprights to Mark Drill Locations on Bases: Loosen the bolts at the top of each upright so you can align the uprights where they will be installed. Tap the top of the legs with a rubber mallet so both legs are vertical with a level. Double check that the T-Top is in its final position for installation and the legs are vertical. Do not worry about the canopy frame being centered as it will be removed for final installation. Keep the bases from moving until after you have marked and drilled the holes. Use a marker or pencil to mark the four drill locations in each base. **Use the marks to make sure the bases do not move until after all the holes are drilled.**

Drill Base Screw Locations: Understand the following procedures before drilling to ensure a clean hole through the deck. Boats have a very hard gelcoat surface with fiberglass under the gelcoat as shown. There may be wood, fresh water tanks, fuel tanks or wiring under the fiberglass so remember to drill only 1" deep for rear bases and 1.5" deep for the front bases. Mark this point on the drill bit with a piece of tape.

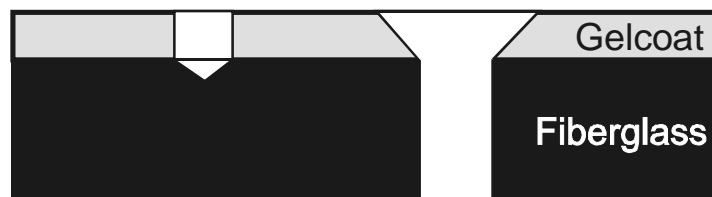

The gelcoat is a very thin layer approximately 1/16th thick and the fiberglass below it is normally about 3/8" thick. The floor near the center console may also have wood or composite sheet material below the fiberglass. **You should ALWAYS run the drill in reverse while drilling.** This keeps the fiberglass from splintering or cracking. Finish the hole by putting a slight angle (chamfer) on the edge of the gelcoat turning the 3/8" drill bit **by hand** (without the drill) as shown on the right side in the above diagram to further protect the boat.

During the drilling is a great time to have someone with the vacuum to remove the fiberglass as you are drilling. **To drill the holes follow the above procedure with the 11/64" drill bit.** Make sure the bases do not move during drilling.

After drilling all the base holes, move the T-Top forward or aft about 6" so you have access to the holes. Use a 3/8"bit to chamfer the hole as shown in the below image. Optionally, you can use a small piece of sand paper to radius the edge of the chamfer also to remove the slight edge. Removing this edge will prevent stress cracking around the holes.

NOTE: If you have a side console door that interferes with the lower leg when opening refer to Appendix B to replace the side door hinge with alignment pins.



Put 3M 5200 Adhesive in Holes and Base Location: The 3M 5200 Marine Adhesive is a key structural part of any T-Top installation. Squirt 5200 into each hole and be sure it is filled with 5200. Then add a smooth layer about 1/16" thick between the four holes. The majority of the strength comes from the screws being bonded to the hole and the base being bonded to the deck adds additional strength. This should look like the image below.



Return Bases of T-Top to Hole Locations and PARTIALLY screw in the Items 4 & 5 Sheet Metal Screws: It is easiest to have one person on each side lift the T-Top into position and slowly lower it to the base locations while you first install one screw into each base. **Once one screw is in each base screw the rest of the screws in but leave each screw out 1/4" as shown below until the standoffs are installed.** It takes hours for the 5200 to begin to cure so don't worry about the screws becoming bonded into the holes. Wipe up any excess 5200.

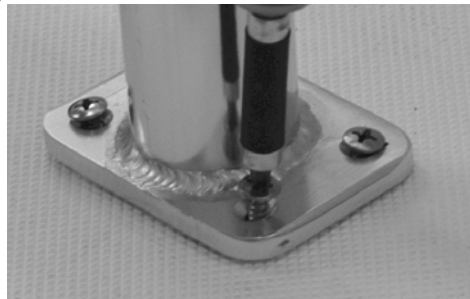

Remove the Frame Canopy to Complete the Standoff Installation: Once the bases are partially screwed into the deck of the boat remove the Four (4) upper leg clamps and the Canopy Frame as shown below. The reason for this is moving the clamps on the top section frame during alignment will scratch the finish of the aluminum. This also allows the legs to be more accurately aligned vertically.



Install Standoffs on Console: The next step is to install a standoff on either side of the console. Note the parts of the standoff assembly in the photo below. Look under the console to determine a location suitable for the backing plate shown below avoiding any wiring or obstructions under the center console.

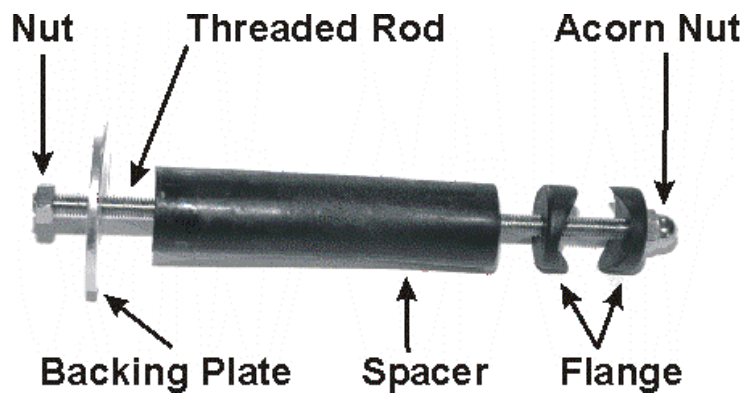



Make sure there are no obstructions where the backing plate will be located.



Use the 3/8" bit to drill through the T-Top leg and center console as shown. Use a center punch to locate the hole on the tube and drill first with the 11/64" bit. If needed you can drill the hole in the console from above and below the cross tube. If you do this first drill from both directions with the 11/64" bit then both directions with the 3/8" bit.

Measure for the spacer making sure the leg is vertical using a level. Cut the spacer to fit and remember it's easier to cut or sand a little more material off then to add a washer.



Complete the first standoff installation using Loctite tightening both the Acorn Nut and Backing Plate Nut.

Follow the same directions to complete the standoff installation on the other side of the console ensuring the leg is vertical.

Tighten all Base Screws: Tighten all sixteen (16) base screws. Do not over tighten and if you hear noise stop.

Center and Install Frame Canopy to Legs: Center the Canopy Frame over the Upper Leg Clamps for final installation. Start but do not tighten each Item 1 bolt into the Upper Leg Clamps then tighten the bolts keeping the gap on each side of the clamp equal.

Before putting the canvas on the frame, polish the entire t-top frame with supplied tube of Flitz Aluminum Polish. Periodically apply Flitz Polish or a comparable aluminum polish to the T-Top frame to help prevent oxidizing or pitting. Always wash the T-top frame after each use.

Center Cover to Canopy Frame: The next step is to center the cover onto the Canopy Frame with the Sunbrella label to the rear of the boat. Use tie wraps, zip ties or rope on each corner as shown below, as well as one each side keeping the gap between the fabric and frame equal all around.

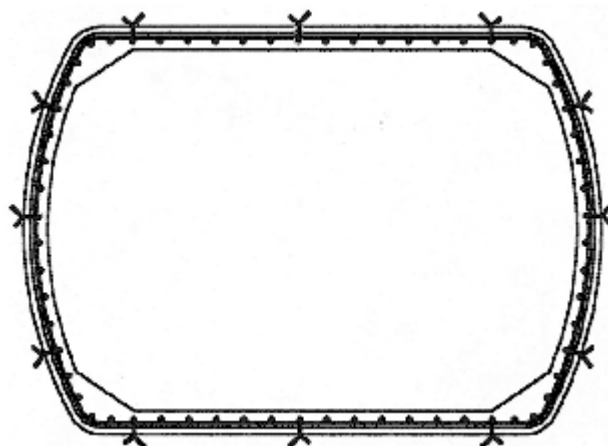

Install Rod Holders: If you purchased rod holders install them before the final lacing of the cover per the rod holder instructions. The rod holders should be centered between the cover grommets and equally spaced.

Lace Cover to Canopy Frame: The next step is to lace the cover onto the Canopy Frame. We recommend starting in the center at the front of the T-Top and tie off the rope to the frame or as shown. Then lace half of the fabric to the center in the back snug but not tight enough to move the fabric. The second half of the lacing will be done tighter to tension the fabric.

There should be approximately ½ inch space between canvas and rail once complete.

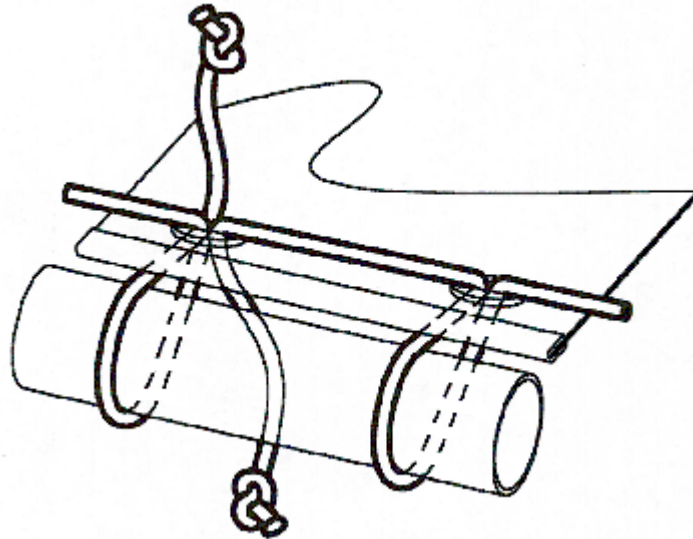

Lacing Steps

- Go top down through the grommet
- Go under the edge of the fabric but over the tube
- Go bottom up through the grommet
- Move to the next grommet and repeat

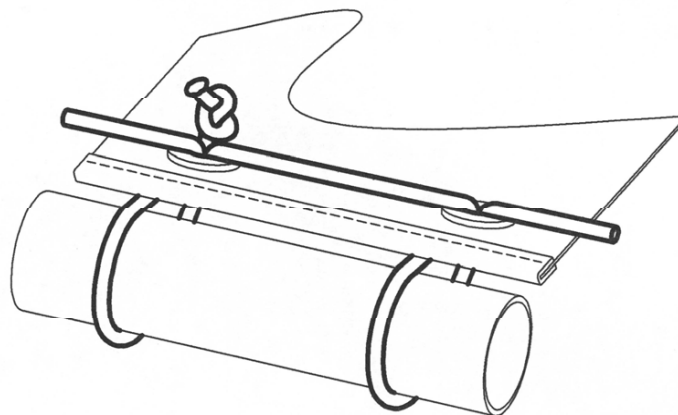

The complete lacing will look the same as above.

You can now go back pulling the lacing between the grommets and tighten the fabric if needed. After the first few uses the fabric will need to be retightened by this method.

Remember to send us a few pictures of your boat with the Fishmaster T-Top installed AND YOUR SHIRT SIZE for a free Fishmaster T-Top T-Shirt. International customers will need to cover the shipping cost. We also sincerely appreciate any feedback on our products, manuals, website or any other customer recommendations

Using your Fishmaster T-Top – Operating Instructions

The Fishmaster T-Top folds down for storage. It is no problem to trailer with the T-Top up. If you fold the T-Top down for trailering make sure to tie it down well so the wind can not move it. To fold the tower down remove two bolts at each corner of the legs and fold the T-Top forward. If the T-Top rests on fiberglass, use a vest or other cushion to protect the boat and T-Top. If you need to also fold the Frame Canopy remove the two outside bolts on each side leaving the center bolt in as a hinge point.

- Remember to protect your boat and T-Top when the tower is folded down. We recommend using a koozie, vest or other padding between any locations where the T-Top touches your boat to protect each item.
- When towing your boat the Fishmaster T-Top can be in the up or folded position. If you tow with the T-Top up, note the height of the T-Top and make sure you have overhead clearance. If you tow with the T-Top down make sure you have pads where the tower touches the boat and the T-Top is securely tied into place.
- The Fishmaster T-Top is stiff and silent by design. If you hear any rattling or noise from the T-Top check all hardware for tightness. Call us at 877-777-Tower if this does not correct the problem.

- Always understand and follow the warnings on the T-Top warning label

Fishmaster T-Top, Inc. - 5 Year Warranty - Fishmaster T-Top warrants that for a period of 5 years from the date the T-Top is sold at retail, that Fishmaster T-Top will repair directly, or supply parts for the repair of any material cracks, fractures or structural failures that are a result of a manufacturing defect. Anodizing and powder coated surfaces as well as all hardware corrosion are specifically excluded as their care and use cannot be controlled by Fishmaster. Any modifications or improper use, not approved in writing by Fishmaster, shall void this warranty. Fishmaster is not responsible for personal injury or damage to the boat caused by the use of this T-Top. Fishmaster's obligation under this warranty shall not include any transportation charges or costs of installation or any liability for direct, indirect or consequential damages resulting from delay or improper installation of the T-Top. Instead of reading all this fine print, get your T-Top on the boat and go fishing! No dealer, retailer or manufacturer is the agent of Fishmaster and may not assume for Fishmaster any liability in connection with this warranty. This warranty is in lieu of all other warranties, expressed or implied, including any warranty of merchantability or of fitness for a particular purpose. If you need to make a warranty claim contact Fishmaster at 877-777-Tower to receive a return authorization number which is required for all claims. Defects must be reported within 30 days of receipt.

We provide a 30 day - No Questions Asked "Love it or Return it" Money Back guarantee. Simply ship it back with a note on why you are returning it and we will refund your money, less our cost to ship the product to you.

APPENDIX A - Wiring Instructions for your Fishmaster T-Top

If you add speakers, lights, antenna or other items to your Fishmaster T-Top, you can hide the wires inside of the tubing of the T-Top. When wiring and you get to the hinge's drill a hole 1 inch above the weld on the top section and drill a hole 1 inch below the weld on the bottom section. Loop the wire out of the tubing of one section and back into the tubing in the other section. Leave 5 – 6 inches of wire out in order for the t-top to fold. The hole size will depend on what size wire and connector you are running and how many items you need to wire. The maximum hole size we recommend is 1/2 inch but normally smaller is all that is needed.

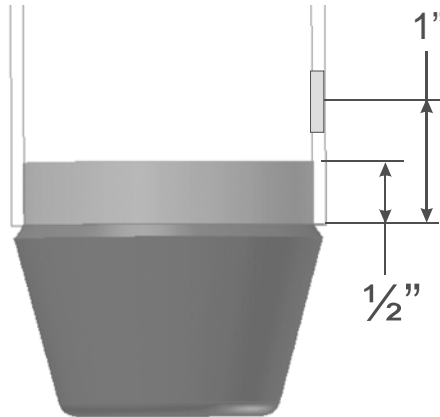

ADDITIONAL RESOURCES OF INTEREST

The various connectors, finishing grommets and items you will need for wiring lights and speakers can be found at Radio Shack, Home Depot, Lowe's, Ace and other hardware stores. You can also find much of this at www.WayTekWire.com as well as many other online sources. There are some great technical documents at www.installdr.com that may be of assistance as well. If you are interested in making your own speakers or other items for your T-Top, check out www.diyTower.com.

APPENDIX B - Side Door Hinge Replacement

For boats with side console doors that interfere with the lower leg, you will need to replace the hinge with pins to slide the door in and out of locked position. Remove the door by removing the screws that hold the hinge to the console. Replace two to three screws with stainless dowel pins (available at Ace, Home Depot, Lowes, etc) that are about the same diameter as the screws. You may need a drill the same size as the dowel, normally both will be 1/8 inch or 3/16 inch diameter. Drill into the door and secure the dowel about half way in with a very small amount of 5200. Drill the console at the mating position and open the hole up slightly with the drill for easy clearance. You can now slide the door into and out of position.



This has worked great for all the boats we have encountered. If you have a different type hinge or door style, please contact us for assistance. If you could email us pictures we will be happy to help determine the best way to make it easy to remove and replace your console door.